



## Magnum Ashva MaK-1 Pump Control Panel - Three Phase

### Introduction

Magnum Ashva MaK-1 Pump Control Panel T.P. gives a powerful performance packed in a compact enclosure. Powder Coated MS Enclosure, Porcelain Connectors, Digital Metering, Bhaiyya Preventor and ever reliable combination of MaK-1 Contactors and O.L Relay – make Ashva truly a horse for the long run.

### Applications

Magnum Three phase DOL Pump Panels/Starters are reliable "Workhorses" for domestic, agricultural and industrial applications. Magnum DOL T.P Controllers are found in many applications such as drainage, sewage pumping, general industrial pumping and slurry pumping.

Also used to control,

- \* Pumps/Motors
- \* Fans
- \* Compressors, lathes and other machinery
- \* Stirrers and mixers

### Functions

- 1.Switches your pump/ motor on and off.
- 2.Protects the pump/motor from over-current, single and reverse phasing.
- 3.Convenience of Auto - Start when power resumes.
- 4.Indication of power supply to the panel.
- 5.Digital display of Volts and Amps

### Salient Features

- 1.Powder coated MS enclosure for corrosion resistance & sturdiness.
- 2.Rugged MaK-1 Contactor with wide voltage band (250V to 440V).
- 3.Fitted with MaK-1 type relay for reliable overload protection.
- 4.Fitted with Magnum Bhaiyya Single Phasing Preventor and Auto Start - protects motor from single phasing and phase reversal conditions.
- 5.Ergonomic design with aesthetic looks.
- 7.Fitted with Digital Meter to inspect the motor current and incoming power supply.

### Technical Specifications

- 1.Enclosure: Powder Coated Mild Steel
- 2.Current: AC
- 3.Operating Voltage: 70% to 105% of coil voltage
- 4.Pick up voltage: Minimum 70% of coil voltage
- 5.Drop off voltage: Below 50% of coil voltage
- 6.Contactor: MaK-1 / MaK-1 Heavy Duty 4 Pole
- 7.Relay: MaK-1 4 Pole
- 8.Area 276\*216\*122 mm
- 9.Net Weight: 3.64 Kilograms
- 10.Insulation Voltage AC (Vi): 660V
- 11.Frequency & Ambient Temperature: 50Hz & (-25°C to +55°C)
- 12.Terminal Capacity: 1 \* 16 mm<sup>2</sup> or 2 \* 10 mm<sup>2</sup>
- 13.Power range: 1.5/2/3/5/7.5/10 HP
- 14.Coil Voltage: 440 V
- 15.Phase: 3 Phase
- 16.Number of cable entries: 1+1 (top+bottom)
- 17.Enclosure cover: Fixed
- 18.Country of origin: 

**Circuit Diagram**

**Mounting Template (mm):  
(Not to Scale)**

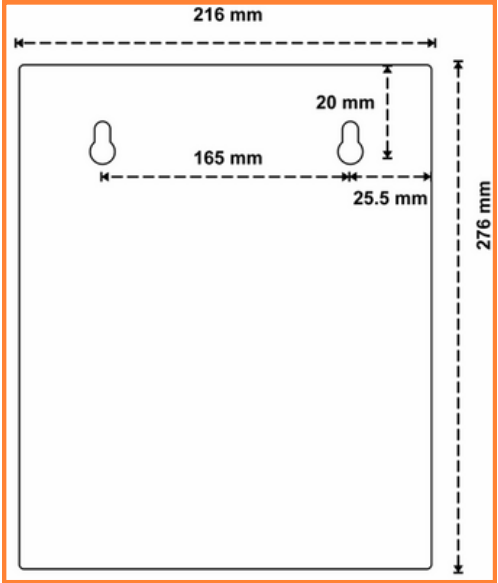
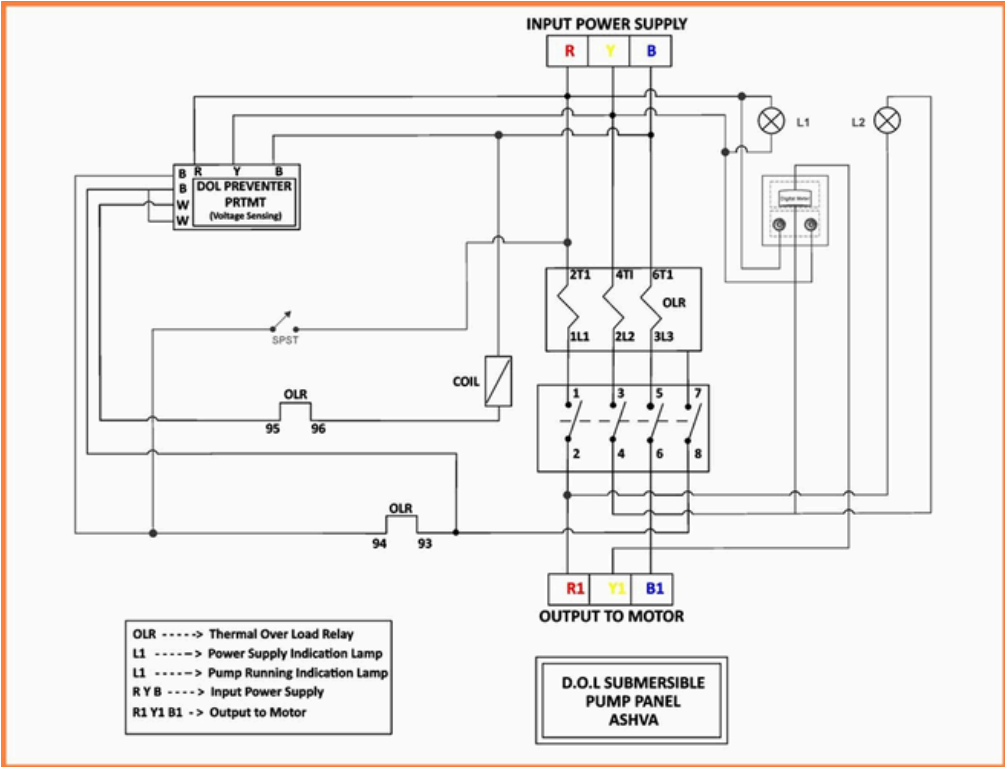

**Selection & Ordering info.**

<b>Power (H.P)</b>	2	3	5	7.5	10
<b>Relay Range (Amps)</b>	4-6.5	6-10	9-14	13-21	20-32
<b>MaK-1</b>	PTAK2	PTAK3	PTAK5	PTAK7H	PTAK10
<b>Standard Pkg.</b>	4/range				

**Links**

Product page - <https://kalpcontrols.com/product/ashva-motor-pump-control-panel/>  
 Video url - <https://www.youtube.com/watch?v=HOHN33XRaYI>