



Magnum SANKET Metering Panel

Introduction

Magnum Sanket Metering Panel Panel is a powerful metering device for three phase applications like DOL motors made with high quality of raw materials.

Functions

1. Indication of current drawn by the motor.
2. Indication of voltage supplied to the panel.
3. Individual Indication lamps for phase voltage supply indications.

Salient Features

1. Powder coated MS enclosure for complete corrosion resistance & sturdiness.
2. Heavy Duty Components and Wiring.
3. Ergonomic design with aesthetic looks.
4. Indication lamps for voltage supply all the three phases.

Technical Specifications

1. Rated Operating Voltage: 380-440V
2. Area: for Standard = (200*118*75) mm
3. Net Weight: 0.84 Kilo grams
4. Frequency: 50Hz
5. Insulation Voltage Ac (Vi): 660V
6. Ambient Temperature: -25°C to +55°C
7. Terminal Capacity: 1 * 16 mm² or 2 * 10 mm²
8. Current: AC
9. Number of cable entries: 1+1 (right + left)
10. Enclosure: Detachable
11. Country of origin: 

Applications

Magnum three phase metering panels are reliable measurement devices for domestic, industrial and agricultural installations. They may be used for metering of –

- DOL Motors
- Pumps
- Across any three phase device

Circuit Diagram

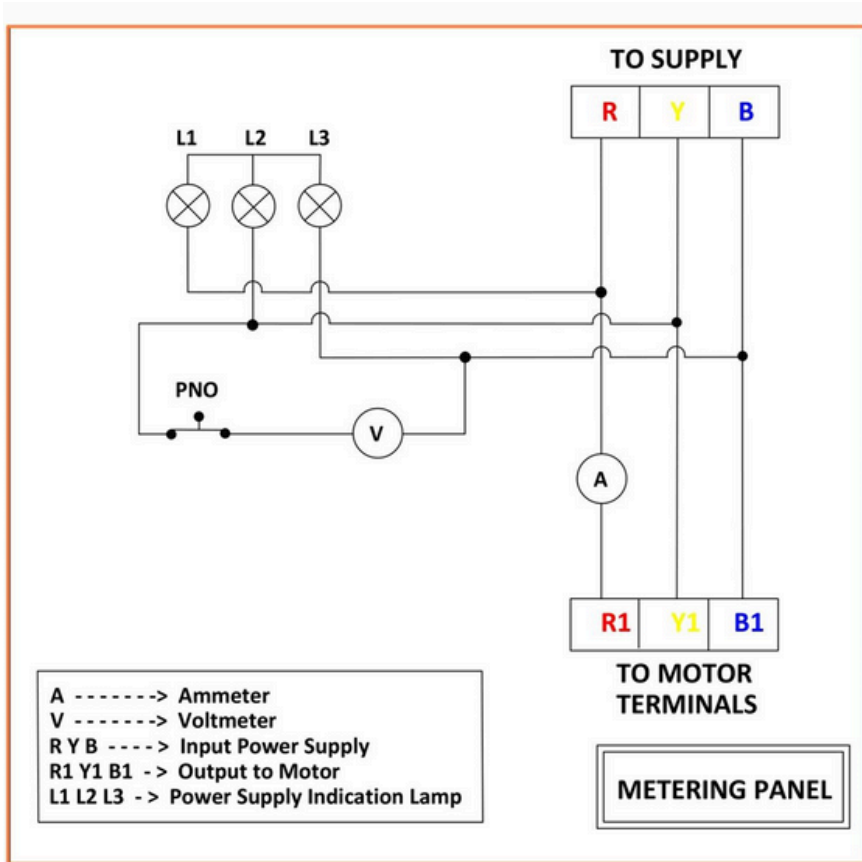

Selection & Ordering info.

Cat Number	MPS30	MPS60
Rating	30A, 500V	60A, 500V
Std.Pkg.	8/range	
Carton Pkg.	18	

Mounting Template (mm): (Not to Scale)

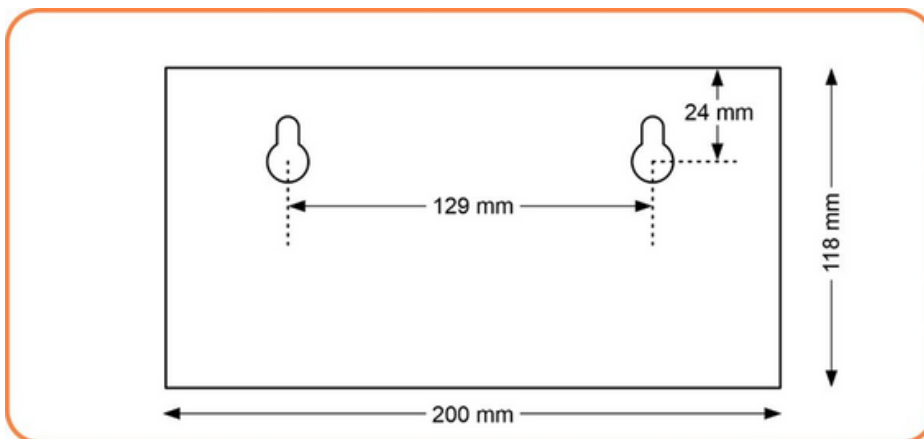

Links

Product page - <https://kalpcontrols.com/product/metering-panel-standard/>

Video url - <https://www.youtube.com/playlist?list=PLOXFfzEEAifl1O6XetAt5LwRnIFqmmPP2>